

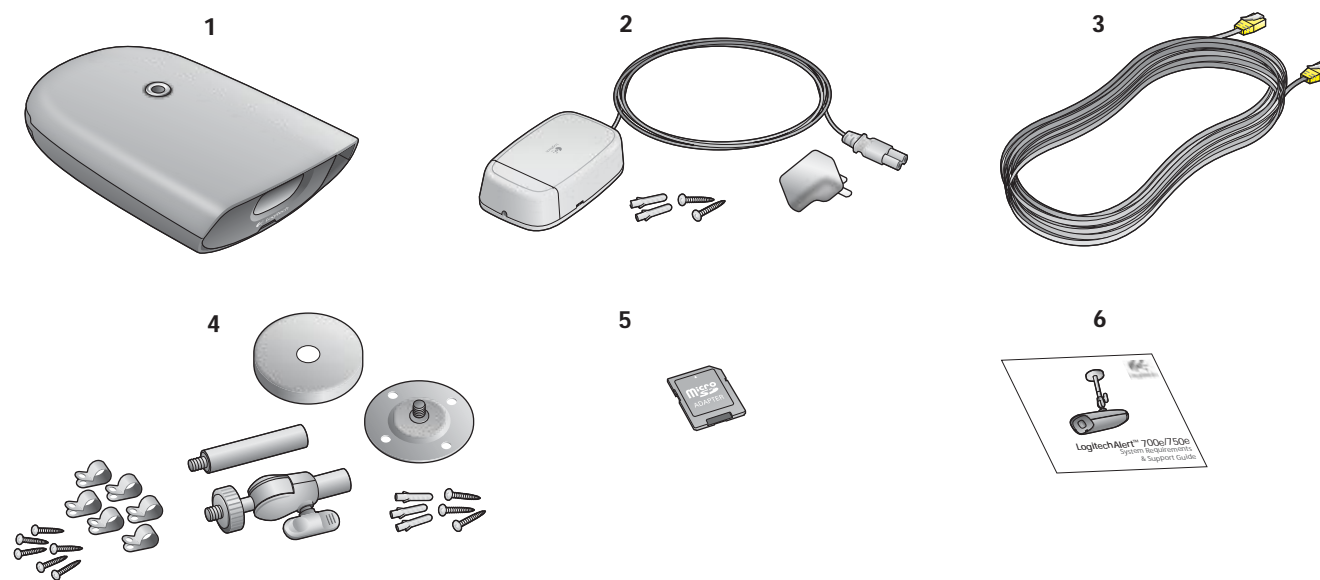

Add-On Camera



1 Logitech Outdoor Camera
2 Camera power supply
3 Power supply cable (yellow tips)
4 Mounting accessories
5 microSD™ card adapter
6 System Requirements Guide



Legal Warning

Certain uses of security camera products and audio devices, such as employee monitoring, surreptitious viewing and recording of images and/or audio, or the use, publication or distribution of image and/or audio recordings, are prohibited or restricted by country, state and local laws.
Be sure to comply with the laws in your country, state, and locality when using Logitech Alert products and services.

1 Run Logitech Alert Commander

Before you begin the installation, read all instructions.

! Logitech Alert Master System required.



1) Be sure that Logitech Alert Commander software is running on the PC before beginning installation of camera.

2 Plug in Your Camera

When prompted to connect your camera:

- 1) Unscrew the hatch from the back of the camera and lift.
- 1a) Plug the yellow cable connector into the port.
- 1b) Screw the hatch firmly in place.

- 2) Unscrew the hatch from the power supply.
- 2a) Plug the yellow cable into the power supply port.
- 2b) Screw the hatch firmly in place.
- 2c) Mount the power supply unit to the wall.
- 2d) Plug the power connector into the plug slider and plug the power supply into an outlet.

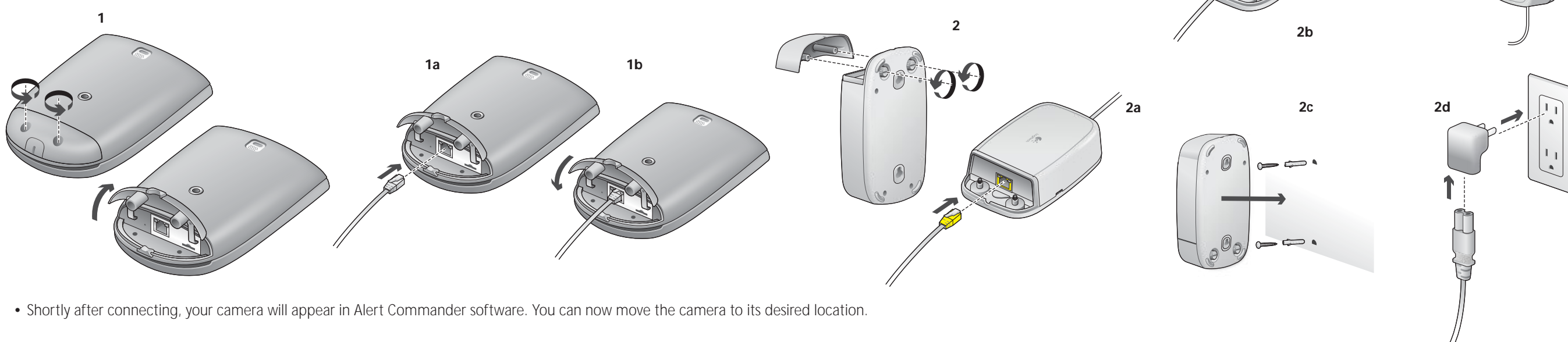

• Shortly after connecting, your camera will appear in Alert Commander software. You can now move the camera to its desired location.

Power Supply Install Note

The power supply unit is weatherproof and can be installed outdoors. Use these tips to ensure reliable power supply usage. Make sure the outdoor outlet is weatherproof. Do NOT place on the ground.

- 1) Do NOT plug the power supply into a surge protector or power strip as they interfere with the cameras. Surge protectors are built-in to the power supply and protect the cameras.
- 2) Do NOT plug the power supply into the wall so that it lays horizontally or flat.
- 3) Do NOT mount the power supply upside down. Keep the cable connector port on the bottom.

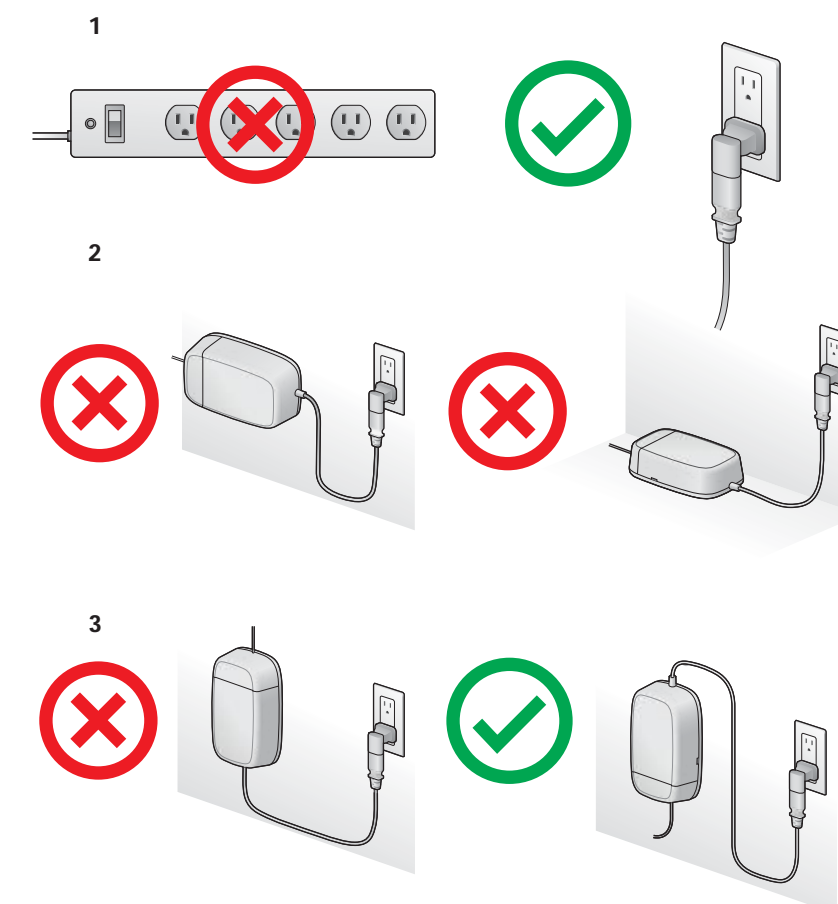

4) Avoid direct sunlight.

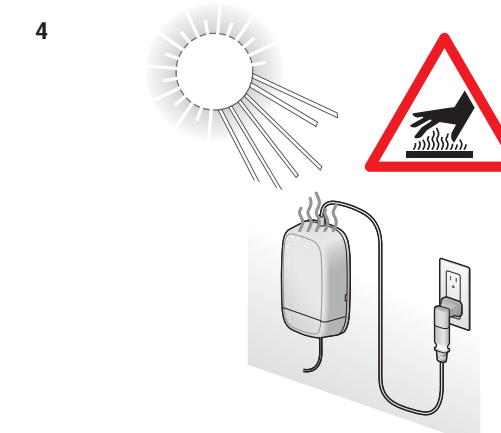

! CAUTION: If left in sunlight, surface may be hot to the touch.

Wall/Ceiling Mounting Instructions

The wall mount allows you to easily fasten your camera to a wall, post, overhang, or other surface.

- 1) Start by pre-drilling holes into the base surface and then fastening the mounting base with the included screws.
- 2) Assemble the mounting arm and attach it to the base.
- 3) Attach the camera to the mounting arm.

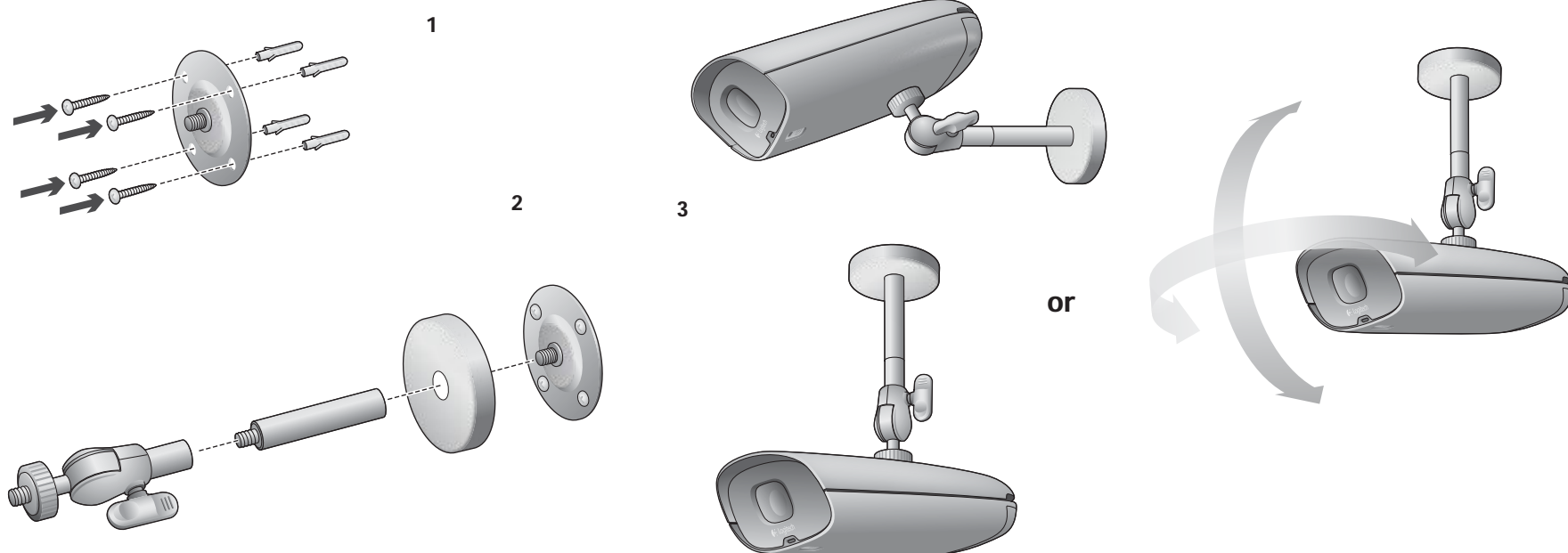

RECOMMENDATION:

Mount the Outdoor Camera under an eave or other overhang so that it is not exposed to direct sunlight.

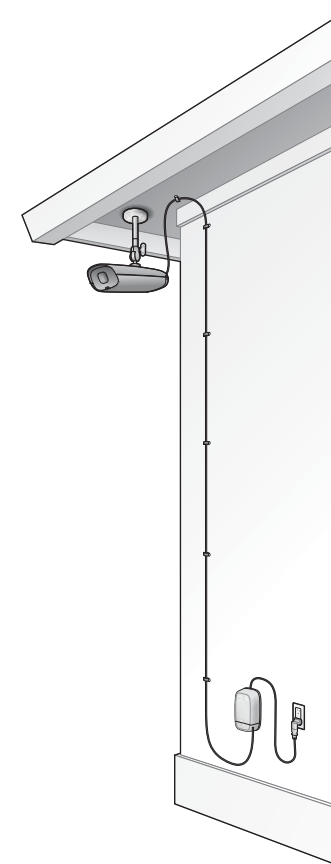

FAQs

Where can I find more information?

Commander Help

You can press the F1 key from any screen in the Alert Commander to access the online Help system.

HELP

Knowledge Base

Troubleshooting help is available at www.logitech.com/support

Customer Support

Call 1.888.469.4543

Refer to System Requirements Guide.

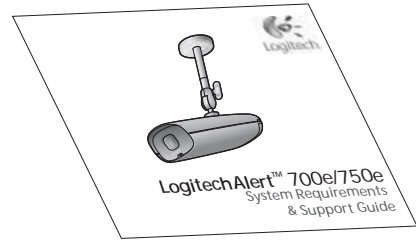

What do I do if I need a longer power supply cable?

Logitech CAT-5e cables have been specially designed to create a weatherproof seal when attached to the camera and power supply. We do not recommend using after market cables. Longer cables are available for purchase at www.logitech.com/dvs/ (Accessories).

Troubleshooting camera connection:

What if camera/video disappears?

- 1) Test another outlet for your camera, perhaps one closer to your PC.
- 2) Verify that the camera power supply and the network bridge are plugged directly into a power outlet and not a power strip.
- 3) Check firewall settings or press the F1 key in Commander Software for additional help.
- 4) Go to Settings > Cameras > Add/Find > Find Cameras.
- 5) Reset the camera. See instructions in "Camera Reset Instructions."

Want to see more FAQs?

Go to www.logitech.com/security/support

Camera Reset Instructions

Insert a paper clip into the reset hole located on the back of the camera and press gently and then release.



If the camera does not appear after reset, go to Settings > Cameras > Add/Find > Find Cameras. If the camera still does not operate, contact technical support.

Resetting the camera will not delete video recorded on the microSD card.

Reading the Diagnostic LEDs



Motion LED

How do I know the camera is recording?

- Camera is ready to record (Red)
- Camera is recording (Red, blinking)

Turning Off Motion and Diagnostic LEDs

You can turn off the motion and diagnostic LEDs in the Settings > Camera dialog.

See F1 Help for instructions.

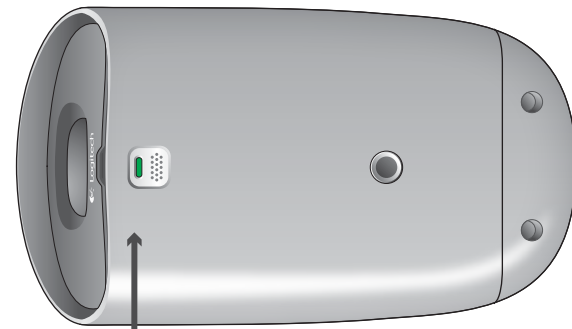

Camera Diagnostic LED

Which LED colors indicate "camera is working"?

- Connected to Internet (Green)
- Connected to Alert Commander (Purple)
- Connected to Alert Commander & Internet (Blue)
- Upgrading Firmware (White)
- Camera in standalone mode (Yellow)
- Not connected to Alert Commander or Internet (Light Blue)

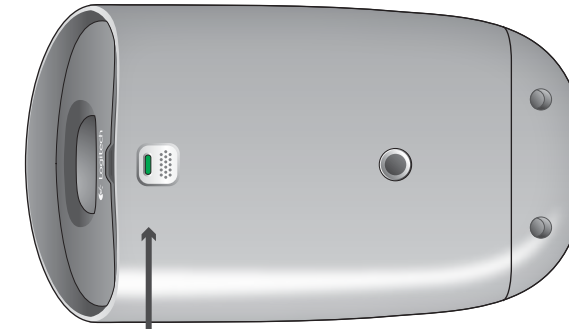

Camera Diagnostic LED

Which LED colors indicate "camera is not working"?

- Camera boot-up failed * (Red blinking)
- microSD card read/write failure - No microSD card * (Alternating Red / Yellow, blinking)

* See Camera Reset Instructions for assistance.



Power Supply Diagnostic LEDs

Power Supply Status LED

What do these LEDs tell me?

- Traffic and data is flowing (Green)
- Connection with Ethernet/LAN (Yellow)

What do these LEDs tell me?

- Link to Power Supply (Green)
- Shows network traffic (Blue)

Using the microSD™ card adapter

NOTE: Unplug the camera before removing, replacing, or upgrading your microSD card.

microSD card comes pre-installed.

To review the video on the microSD card, we recommend you using Logitech Alert Commander.

To review the video on the microSD card without Logitech Alert Commander:

- 1) Open the hatch on the bottom of the camera and remove the microSD card from its port.
- 2) Plug the microSD card into the adapter.
- 3) Plug the adapter into the PC's SD card slot.

- View video recordings using the free Apple QuickTime player or other player that supports H.264 video playback. (To download QuickTime, visit <http://www.apple.com/quicktime/download/>)

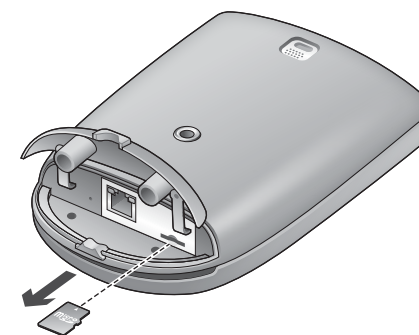

1

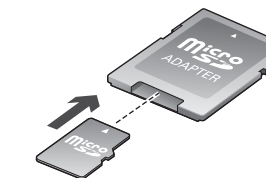

2



3



microSD card must be installed in the camera for recording to occur.

www.logitech.com

© 2010 Logitech. All rights reserved. Logitech, the Logitech logo, and other Logitech marks are owned by Logitech and may be registered. All other trademarks are the property of their respective owners. Logitech assumes no responsibility for any errors that may appear in this manual. Information contained herein is subject to change without notice.

620-002016 rev005

microSD Logo is a trademark of SD-3C, LLC.